

9.1 分解圖、零件表

PARTS LIST

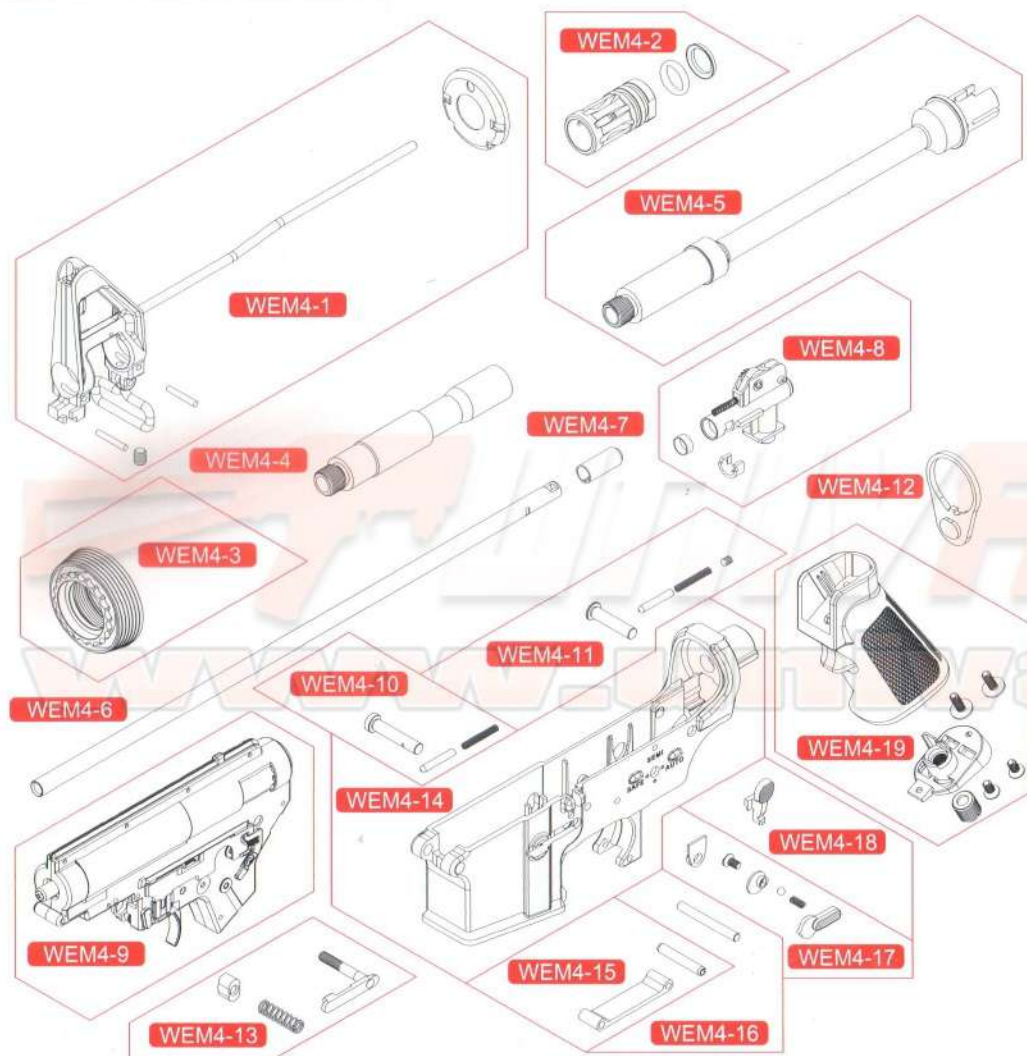

NO.	品名 Parts name
WEM4-1	準星組 Front Sight Set
WEM4-2	防火帽組 Flash Hider Set
WEM4-3	固定環組 Fixing Ring Set
WEM4-4	槍管前段 Front Barrel
WEM4-5	槍管後段組 Rear Barrel Set
WEM4-6	內槍管 Inner Barrel
WEM4-7	上旋系統橡皮 Hop-Up Rubber
WEM4-8	上旋系統組 Hop-Up Set

NO.	品名 Parts name
WEM4-9	齒輪箱組 Gear Box Set
WEM4-10	前插梢組 Front Pivot Pin Set
WEM4-11	前插梢組 Front Pivot Pin Set
WEM4-12	槍托連接蓋板 Receiver End Plate
WEM4-13	彈匣卡榫組 Magazine Catch Set
WEM4-14	下槍身 Lower Receiver
WEM4-15	扳機護弓組 Trigger Guard Set
WEM4-16	扳機插梢 Trigger Lock Pin

9.2 分解圖、零件表

PARTS LIST

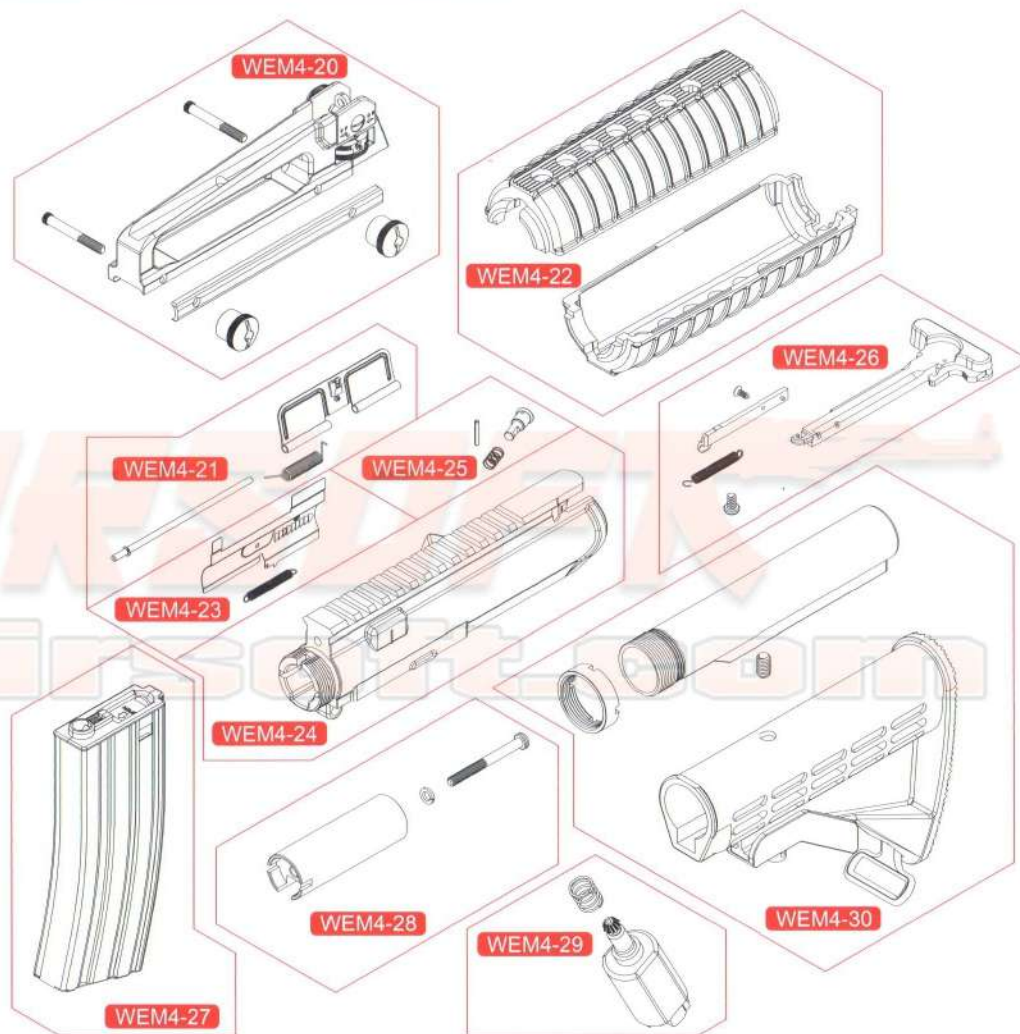

NO.	品名 Parts name
WEM4-17	射擊選擇鈕組 Selector Lever Set
WEM4-18	槍機卡榫 Bolt Catch
WEM4-19	握把組 Pistol Grip Set
WEM4-20	提把組 Carrying Handle
WEM4-21	防塵蓋組 Ejection Port Cover Set
WEM4-22	護木組 Handguards Set
WEM4-23	槍機飾片組 Dummy Bolt Set
WEM4-24	上槍身組 Upper Receiver Set

NO.	品名 Parts name
WEM4-25	槍機助進器組 Forward Assist Knob Set
WEM4-26	槍機拉柄組 Charging Handle Set
WEM4-27	300發彈匣 300rd Magazine
WEM4-28	伸縮托桿組 Stock Tube Set
WEM4-29	馬達組 Motor Set
WEM4-30	伸縮托組 Retractable Stock Set

9.3 分解圖、零件表

PARTS LIST

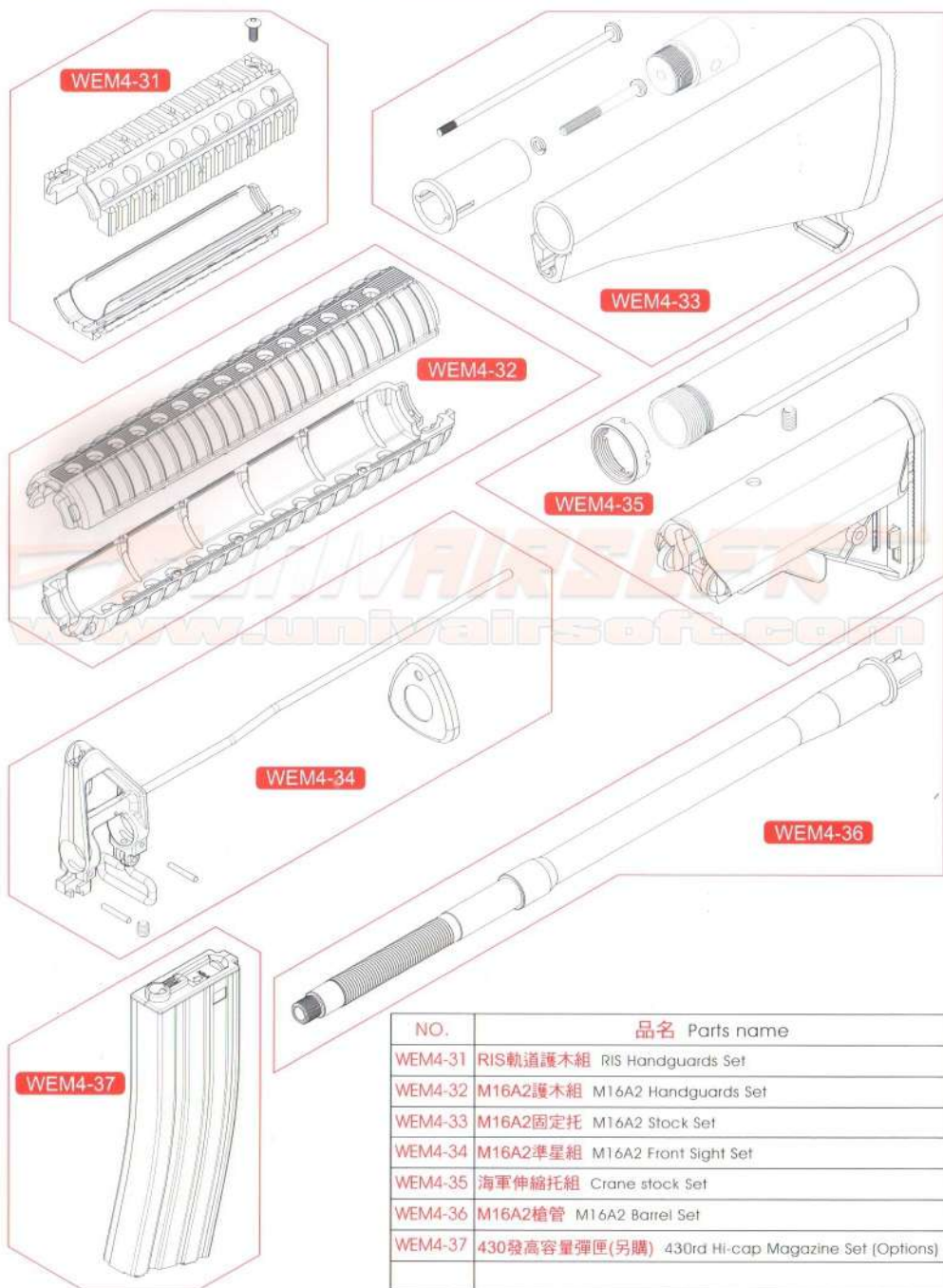

10. 故障診斷

TROUBLE CLINIC

狀況 SYMPTOM	原因 CAUSE	處理方式 ACTION
無法作動 No operation at all	選擇鈕設定在SAFE的位置 Selector lever set to SAFE.	將選擇鈕切換到半自動或全自動 Set the selector to AUTO or SEMI.
	電池沒電 Battery is dead.	電池充電 Charge the battery.
	電池接頭脫離 Battery connector is disconnect.	接頭確實接牢 Connect the connector.
	馬達標準壽命已到(約5萬發) Expired the motor life. (about 5 million rounds)	更換馬達 Replace the motor.
	保險絲燒毀 Fuse is blown out.	更換保險絲 Replace the fuse.
馬達有動作卻不能擊發 Motor is revolving but gun doesn't work	齒輪或內部零件損壞 Gear or internal components of damage.	請至專賣店維修 Purchase the replacement parts from the dealer.
	彈匣卡彈 Bullets are clogged in the magazine.	請輕拍彈匣並使用高品質BB彈 Shake the magazine and use high quality BB bullets.
	槍膛卡彈 Bullets are clogged in the chamber.	使用通槍條通出BB彈 Using the clearing rod to remove the bullet.
單發不正確 Malfunction of semi auto	齒輪正時未對準 Deviation in gear timing.	切換至連發射擊2-3秒後再切回單發 Firing 2-3 sec in the full auto mode and then return to the semi auto.
	單連發撥桿損壞 Cut off lever damage.	請至專賣店維修 Purchase the replacement parts from the dealer.
連發不正確 Malfunction of full auto	齒輪正時未對準 Deviation in gear timing.	切換至單發射擊2-3發後再切回連發 Firing 2-3 shots in the semi auto mode and then return to the full auto.
	單連發撥桿損壞 Cut off lever damage.	請至專賣店維修 Purchase the replacement parts from the dealer.
連發速度變慢 Firing circle slow	電池即將沒電 Deviation in gear timing.	電池充電 Charge the battery.
BB彈飛行距離變短或未擊發時由槍口掉落 Shooting distance becomes shorter or not fired when falls by the muzzle.	上旋系統未調整 Hop-Up system unadjusted.	調整上旋系統 Adjusted the hop-up.
	BB彈不良 Faulty BB bullets.	請使用高品質BB彈(勿使用回收彈) Please use high quality BB bullets. (Do not use the recycling bullets)
	活塞O環磨損 The piston o-ring worn off.	請至專賣店維修 Purchase the replacement parts from the dealer.
作動聲音異常 Overly loud operating noise.	齒輪或內部零件損壞 Gear or internal components of damage.	請至專賣店維修 Purchase the replacement parts from the dealer.